

The Competition Handbook



INTRODUCTION:

This Handbook details the competition procedures and rules of Little Athletics Queensland (LAQ) and modified rules of Little Athletics Australia (LAA) and is intended along with the Officials Handbook and World Athletics rules as a guide for Officials who assist during competitions conducted each season by LAQ and/or its servants at Centres, Regional Competitions, Carnivals and Championships

Some of the rules listed in this handbook may be Resolutions from the LAA or LAQ Conferences or By-Laws from the LAQ Board of Directors.

The Resolutions made at a General Meeting of the Association, can only be changed by another General Meeting. The Association's Annual Conference is the only General Meeting each year at which Policy decisions are made. Resolutions are identified by letters and numbers e.g.

BoD 1 ('00)

The By-Laws can be changed either by the Board of Directors or by an Association General Meeting (i.e. Annual Conference). By-Laws are identified by numbers - year, month and number e.g.

'89 11 01

The Association's Competition Year shall run from 1st April to 31st March, however Centres may choose their own competition period within that year, comprising a maximum 26 weeks of competition within a 30 week block, signing on at a date not more than two (2) weeks prior to the nominated competition period. The competition period must be concluded by the 31st March the following year, unless otherwise approved by the Board. The maximum competition period of 26 weeks is designed to include allowances for washed out meets.

BoM 4 ('03)

1.	SUMMARY OF TRACK & FIELD EVENTS	4
2.	EVENT & EQUIPMENT SPECIFICATIONS	5
2.1.	TRIAL EVENTS	5
2.2.	HURDLES	5
2.3.	RELAY BATONS	7
2.4.	STARTING BLOCKS	7
2.5.	HIGH JUMP	7
2.6.	LONG / TRIPLE JUMP	7
2.7.	DISCUS	7
2.8.	JAVELIN	8
2.9.	SHOT PUT	8
3.	FOOTWEAR & UNIFORM	8
3.1.	FOOTWEAR & SPIKES	8
3.2.	COMPETITION UNIFORMS	9
4.	INJURY & MEDICATION	10
4.1.	INJURY	10
4.2.	MEDICATION	10
5.	THE COMPETITIONS	11
5.1.	COMPETITION LEVELS	11
5.2.	COMPETITION TYPES	12
5.3.	LAQ CARNIVALS	12
5.4.	COMBINED EVENTS & COMBINED EVENT CHAMPIONSHIPS	13
5.5.	THE RELAYS	15
5.6.	REGIONAL & STATE CHAMPIONSHIPS	19
5.7.	LITTLE ATHLETICS AUSTRALIAN CHAMPIONSHIP	20
6.	ELIGIBILITY / NOMINATION	20
6.1.	ELIGIBILITY	20
6.2.	NOMINATION	21
6.3.	LATE NOMINATION	21
6.4.	QUALIFICATION TO STATE CHAMPIONSHIP EVENTS	21
7.	COMPETITION RULES	22
7.1.	GENERAL	22
7.2.	PROGRESSION TO THE NEXT ROUND / FINAL	22
7.3.	CALL ROOM (Marshalling)	23
7.4.	TRACK EVENTS	23
7.5.	WALKS	24
7.6.	FIELD EVENTS	25
7.7.	BEST PERFORMANCES	27
8.	CLASHING & CHANGE OR ABANDONED EVENTS	28
8.1.	CLASH OF EVENTS	28
8.2.	CHANGE OF COMPETITION AREA	28
8.3.	ABANDONED ASSOCIATION COMPETITIONS / EVENTS	28

9.	PROTESTS / DISQUALIFICATIONS / APPEALS	29
9.1.	GENERAL	29
9.2.	PROTESTS	29
9.3.	DISQUALIFICATION BY A REFEREE	30
9.4.	APPEALS	30
10.	OFFICIALS	31
10.1.	APPOINTMENT OF OFFICIALS	31
10.2.	TEAM MANAGERS	31

1. SUMMARY OF TRACK & FIELD EVENTS

1.1 Summary of Standard Competition Events U9-U17s

All events are for boys & girls unless otherwise stated.

EVENTS	U9	U10	U11	U12	U13	U 14	U 15	U16	U17
70 metre	√	√							
100 metre	√	√	√	√	√	√	√	√	√
200 metre	√	√	√	√	√	√	√	√	√
300 metre									
400 metre	√	√	√	√	√	√	√	√	√
500 metre									
700 metre									
800 metre	√	√	√	√	√	√	√	√	√
1500 metre			√	√	√	√	√	√	√
60m Hurdle	√	√							
80m Hurdle			√	√	√	G			
90m Hurdle						B	G	G	
100m Hurdle							B	B	G
110m Hurdle									B
200m Hurdle					√	√			
300m Hurdle							√	√	√
300m Race Walk									
700m Race Walk	√								
1100m Race Walk		√	√						
1500m Race Walk				√	√	√	√	√	√
3000m Race Walk						√	√	√	√
4 x 70 Relay									
4 x 100 Relay	√	√	√	√	√	√	√	√	√
4 x 200 Relay	√	√							
Swedish Relay			√	√	√	√	√	√	√
4 x Medley Relay			√	√	√	√			
1000m Cross Country	√	√	√	√	√	√	√	√	√
2000m Cross Country			√	√	√	√	√	√	√
3000m Cross Country					√	√	√	√	√
4000m Cross Country							√	√	G
6000m Cross Country									B
Long Jump	√	√	√	√	√	√	√	√	√
Triple Jump			√	√	√	√	√	√	√
High Jump	√	√	√	√	√	√	√	√	√
Shot Put	√	√	√	√	√	√	√	√	√
Discus	√	√	√	√	√	√	√	√	√
Javelin			√	√	√	√	√	√	√
Vortex / Turbo Jav									

Legend:
 √ Centre & LAQ Competition
 □ Optional at Centre only

■ Not permitted
 ■ LAA Standard Events (may be eligible for ABP's)

1.2 Standard Development Events (U6 to U8)

1.2.1 All events are for boys & girls unless otherwise stated. Events must not exceed the distances and / or specifications as listed.

Event Type	U6	U7	U8
Race Walks	N/A	N/A	Up to and including 700m
Sprints	Up to and including 100m	Up to and including 200m	Up to and including 200m
Hurdles	60m, max height 20cm (PVC training hurdles)	60m, max height 30cm	60m, max height 45cm
Middle Distances	Up to and including 300m (pack start)	Up to and including 500m (pack start)	Up to and including 700m (pack start)
Throws	Shot Put - 1kg Discus - 350g Vortex - 300g	Shot Put - 1kg Discus - 350g Vortex - 300g	Shot Put - 1.5kg Discus - 500g Vortex or Turbo Jav - 300g
Horizontal Jumps	Long Jump (using mat or sand)	Long Jump (using mat or sand)	Long Jump (using mat or sand)
Vertical Jumps	N/A	N/A	High Jump (scissors only: bar or flexy rope)
Relays	Max leg of 100m	Max leg of 200m	Max leg of 200m

2. EVENT & EQUIPMENT SPECIFICATIONS

2.1. TRIAL EVENTS

2.1.1. Centres at the instruction of the BoD or Conference are able to trial events, event specifications changes, and age groups in Queensland, to take the results of such trials to the Little Athletics Australian (LAA) Conference. Refer to the Association Constitution and the Resolutions and By-laws for implementation of trial procedures.

2.2. HURDLES

2.2.1. Distance and Age Specifications

	U6	U7	U8	U9	U10	U11	U12	U13	U14	U15	U16	U17
60mH (20cm)	BG	---	---	---	---	---	---	---	---	---	---	---
60mH (30cm)	---	BG	---	---	---	---	---	---	---	---	---	---
60mH (45cm)	---	---	BG	BG	---	---	---	---	---	---	---	---
60mH (60cm)	---	---	---	---	BG	---	---	---	---	---	---	---
80mH (60cm)	---	---	---	---	---	BG	---	---	---	---	---	---
80mH (68cm)	---	---	---	---	---	---	BG	---	---	---	---	---
80mH (76cm)	---	---	---	---	---	---	---	BG	G	---	---	---
90mH (76cm)	---	---	---	---	---	---	---	---	B	G	G	---
100mH (76cm)	---	---	---	---	---	---	---	---	---	B	B	G
110mH (76cm)	---	---	---	---	---	---	---	---	---	---	---	B
200mH (68cm)	---	---	---	---	---	---	---	BG	---	---	---	---
200mH (76cm)	---	---	---	---	---	---	---	---	BG	---	---	---
300mH (76cm)	---	---	---	---	---	---	---	---	---	BG	BG	BG

2.3.2. Flights, Spacing and Height Specifications

60m	6 Flights	@	7m spacing, 12m lead in, 13m run out	
			20cm	U6 Boys & Girls
			30cm	U7 Boys & Girls
			45cm	U8 & U9 Boys & Girls
			60cm	U10 Boys & Girls
80m	9 Flights	@	7m spacing, 12m lead in, 12m run out	
			60cm	U11 Boys & Girls
			68cm	U12 Boys & Girls
			76cm	U13 Boys & Girls, U14 Girls
90m	9 Flights	@	8m spacing, 13m lead in, 13m run out	
			76cm	U14 Boys, U15 & 16 Girls
100m	10 Flights	@	8.5m spacing, 13m lead in, 10.5m run out	
			76cm	U15 - 16 Boys & U17 Girls
110m	10 Flights	@	9.14m spacing, 13.72m lead in, 14.02m run out	
			76cm	17 Boys
200m	5 Flights	@	35m spacing, 20m lead in, 40m run out	
			68cm	U13 Boys & Girls
			76cm	U14 Boys & Girls
300m	7 Flights	@	35m spacing, 50m lead in, 40 run out	
			76cm	U15 to U17 Boys & Girls

LAA ('17)

'15 09 09

'15 09 09

'16 07 12

'15 09 09

2.3.3. Any Centre and or Regional Championships Venue that is not able to cater for a full 110m distance shall have the ability to conduct the event over 100m and minus one hurdle flight. In these instances the 110mH flights may be set up so that the run in and spacing meet LAQ 110mH specifications, however the runout would be shorter. '15 09 09

2.3.4. The standard competition hurdle shall be made of metal with the top bar of wood or other suitable material. Hurdles shall consist of two feet and two uprights supporting a crossbar.
 a) Hurdles used for U6s should be made of light weight material e.g. PVC or similar extruded plastics '20 07 14

2.3.5. The hurdle crossbar shall be adjustable in height. The face of the crossbar shall be 7cm in width and shall be 120cm in length. The end of the crossbar shall project 5cm to 7.5cm outside the hurdle frame upright.

2.3.6. Each crossbar should be painted white and have black or coloured stripes painted or taped to the bar.

2.3.7. The hurdle shall be so designed that it shall just resist a force of 2 to 3kgs, applied at the top edge of the crossbar.

2.3.8. Hurdles designed to collapse on contact may have feet that are designed to go on the non-approach side, or straddle the hurdle placement line. '19 05 08

2.3.9. Collapsible type means when a hurdle is knocked down it lays flat on the track without any part of the hurdle protruding.

a) All Centres must be using collapsible hurdles by the commencement of the 2019/2020 season. LAA ('13)

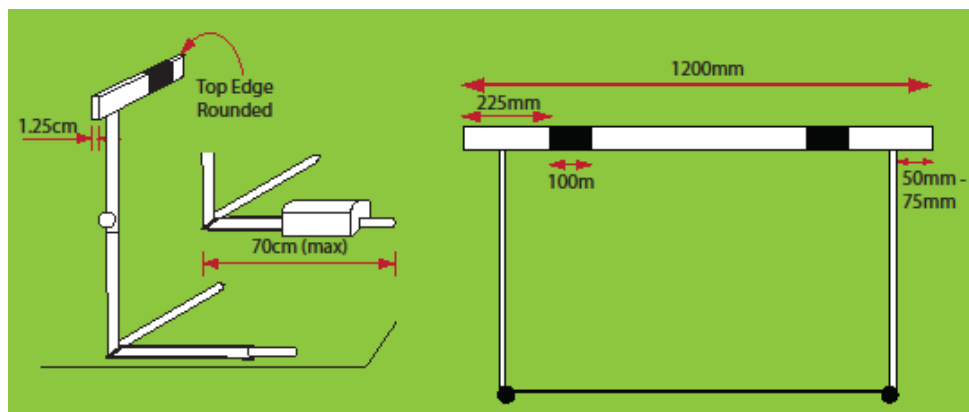

2.3. RELAY BATONS

- 2.3.1. The baton specifications are:
- a) Diameter 32mm (+/- 2mm)
 - b) Length minimum - 280mm, maximum - 300mm
 - c) Weight minimum - 50g

LAA ('17)

2.4. STARTING BLOCKS

- 2.4.1. At the discretion of the Centre Committee, U11 to U17 athletes have the option to use starting blocks at Centre Competitions in laned events up to 400M including the first leg of the relay races. Starting blocks may be provided by the Centre or by the athlete, only if not provided by the Centre. BoD C9 ('14)
- 2.4.2. At the discretion of the Regional Committee, U11 to U17 athletes have the option to use starting blocks at the Regional competitions in laned events up to 400m including the first leg of the relay races. Only blocks provided by the Region shall be used. BoD C11 ('14)
- 2.4.3. U11 to U17 athletes have the option to use starting blocks at the Carnivals and Championships in laned events up to 400m including the first leg of the relay races. Starting blocks to be provided by the Association. BoD C10 ('14)

2.5. HIGH JUMP

- 2.5.1. U8 to U10 Scissors only: onto low scissors mat
- a) The minimum height of scissors jump mats should be 15cm, the maximum should be 30cm.
 - b) The landing area should not be less than 5m x 3m
- 2.5.2. U11 to U17 Scissors or flop technique: onto appropriate thickness and density flop mats. LAA ('16)
- a) The minimum height of the flop mats should be 40cm (preference to 50cm or higher)
 - b) The landing area for the flop should not be less than 5m x 3m

2.6. LONG / TRIPLE JUMP

2.6.1. Age Group Specifications

	U6	U7	U8	U9	U10	U11	U12	U13	U14	U15	U16	U17
Long Jump												
1m x ½m mat	BG	BG	BG	BG	BG	---	---	---	---	---	---	---
1.22m x 20cm	---	---	---	---	---	BG	BG	BG	BG	BG	BG	BG
Triple Jump												
1.22m x 20cm	---	---	---	---	---	BG	BG	BG	BG	BG	BG	BG

LAA ('16)

2.7. DISCUS

2.7.1. Age Group & Weight Specifications

	U6	U7	U8	U9	U10	U11	U12	U13	U14	U15	U16	U17
350g	BG	BG	---	---	---	---	---	---	---	---	---	---
500g	---	---	BG	BG	BG	BG	---	---	---	---	---	---
750g	---	---	---	---	---	---	BG	BG	---	---	---	---
1kg	---	---	---	---	---	---	---	---	BG	BG	BG	G
1.5kg	---	---	---	---	---	---	---	---	---	---	---	B

- 2.7.2. U6 to U17 athletes will use rubber / synthetic compound discus in normal Centre competition.
- 2.7.3. U13 to U17 athletes competing in the Multi-Events or individual discus event at Winter, Regional and State Championships, LAQ Carnivals, Regional Relay or State Relay Championships shall have the choice of a metal rimmed discus (if available) or a rubber discus of the weight relevant to their age group. '10 05 08
- 2.7.4. The weight tolerance shall be between zero and +0.025kg. The tolerance of the diameter shall be within the minimum and maximum listed:
- | | | | |
|-------|-------------|--------|-------------|
| 350g: | 119 ~ 121mm | 1kg: | 180 ~ 182mm |
| 500g: | 134 ~ 139mm | 1.5kg: | 200 ~ 202mm |
| 750g: | 154 ~ 156mm | | |

'19 05 08

2.8. JAVELIN

2.8.1. Age Group & Weight Specifications

	U6	U7	U8	U9	U10	U11	U12	U13	U14	U15	U16	U17
400g	---	---	---	---	---	BG	BG	G	G	---	---	---
500g	---	---	---	---	---	---	---	---	---	G	G	G
600g	---	---	---	---	---	---	---	B	B	---	---	---
700g	---	---	---	---	---	---	---	---	---	B	B	B

2.8.2. The shaft of the javelin shall be constructed completely of metal or other suitable material. The weight tolerance shall be between zero and +0.025kg '19 05 08

2.9. SHOT PUT

2.9.1. Age Group & Weight Specifications

	U6	U7	U8	U9	U10	U11	U12	U13	U14	U15	U16	U17
1kg <i>blue</i>	BG	BG	---	---	---	---	---	---	---	---	---	---
1.5kg <i>yellow</i>	---	---	BG	---	---	---	---	---	---	---	---	---
2kg <i>orange</i>	---	---	---	BG	BG	BG	BG	---	---	---	---	---
3kg <i>white</i>	---	---	---	---	---	---	---	BG	BG	G	G	G
4kg <i>red</i>	---	---	---	---	---	---	---	---	---	B	B	---
5kg <i>green</i>	---	---	---	---	---	---	---	---	---	---	---	B

2.9.2. The weight tolerance shall be between zero and +0.025kg. The tolerance of the diameter shall be within the minimum and maximum listed '19 05 08

1kg:	76 ~ 86mm	3kg:	85 ~ 110mm
1.5kg:	76 ~ 86mm	4kg:	95 ~ 110mm
2kg:	76 ~ 86mm	5kg:	100 ~ 120mm

3. FOOTWEAR & UNIFORM

3.1. FOOTWEAR & SPIKES

3.1.1. Shoes must be worn by all athletes while competing in any LAQ sanctioned track and field competition. Any person seeking exemption from wearing shoes must support their application with a relevant medical certificate on the day of competition, before competing. STP 53 ('02)

3.1.2. No athlete may wear football boots or cleats in an event.

3.1.3. Spikes

- a) At Centre level at the Centre Management discretion, athletes from U11 age group and upwards are able to wear spikes in appropriate events as detailed in the table below.
- b) Athletes in the U6 to U10 age groups may not wear spike shoes.
- c) Athletes in the U11 to U12 age groups may wear spike shoes in long jump, triple jump, high jump and javelin and in events run entirely in lanes. LAA ('15)
- d) Athletes in the U13 to U17 age groups may wear spike shoes in long jump, triple jump, high jump, javelin and in all track events (except walks). LAA ('15)
- e) Needle / pin spikes are prohibited on synthetic tracks at LAQ Competitions including Regional Competitions. '19 05 08
- f) On synthetic track: spikes must be no longer than 7mm.
- g) On synthetic field: spikes must be no longer than 9mm.
- h) On grass track or field: spikes must be no longer than 12mm.
- i) Any number of spikes up to 11 may be accommodated on each shoe, but the number of spike positions shall not exceed 11. LAA ('15)
- j) Spike shoes must be worn with all holes filled with a complete set of spikes, with no more than two blanks / slugs installed. LAA ('15)
- k) Spike shoes must only be worn during an event and are not to be worn to and from an event
- l) Spiked shoes must not be worn in the stand or outer areas of the track.
- m) Spiked shoes should be carried in a suitable bag at all times and stored safely when not in use.



Allowed spike styles

Any athlete not exercising care when using spikes may be disqualified from wearing them for the remainder of the competition.

3.1.4. Age & Event Specifications

	U6	U7	U8	U9	U10	U11	U12	U13	U14	U15	U16	U17
Track												
<i>Laned</i>	---	---	---	---	---	S⚡S	S⚡S	S⚡S	S⚡S	S⚡S	S⚡S	S⚡S
<i>Unlaned</i>	---	---	---	---	---	---	---	S⚡S	S⚡S	S⚡S	S⚡S	S⚡S
<i>Relays</i>	---	---	---	---	---	Ir *	Ir *	S⚡S	S⚡S	S⚡S	S⚡S	S⚡S
Field												
<i>V Jumps</i>	---	---	---	---	---	S⚡S	S⚡S	S⚡S	S⚡S	S⚡S	S⚡S	S⚡S
<i>H Jumps</i>	---	---	---	---	---	S⚡S	S⚡S	S⚡S	S⚡S	S⚡S	S⚡S	S⚡S
<i>Javelin</i>	---	---	---	---	---	S⚡S	S⚡S	S⚡S	S⚡S	S⚡S	S⚡S	S⚡S

Legend:

- S⚡S May wear spike shoes with spikes
 Ir U11 - U12 Athletes competing in 4 x 100m Relays may wear spike shoes with spikes
 * Athletes competing in U13 - U17 Relay teams may wear spike shoes with spikes

3.2. COMPETITION UNIFORMS

3.2.1. When presenting to the Call Room or Competition arena, all athletes must be attired in correct Centre uniform as approved by LAQ. The uniform must be worn in compliance with the items design, e.g. not rolled up or down. Refer to the LAQ Uniform and SunSafe Policies and World Athletics Handbook for further information

- The Registration number is to be affixed to the front of the uniform top and must be entirely visible.
- The age label is to be affixed to the left shirt sleeve or, in the case of a crop top or singlet, on the left side of the shorts or similar.
- The Coles patch must be adhered to the front right chest side of the uniform.

3.2.2. Failure to comply with the uniform rules and policies may lead to the athlete not being allowed to enter the competition arena.

3.2.3. Uniform Infringements

If an athlete arrives at the Call Room or is on the arena and found to be out of uniform, the following procedure shall be followed:

- Athletes in the U13 and older age groups may be approached directly on the arena or in the Call Room and be given a verbal warning for a uniform infringement without the presence of a Team Manager. These age groups are to be advised that they may continue to compete in that event if time does not allow the infringement to be fixed prior the event or that the infringement must be rectified prior to their next event. ^{'17 03 08}
- Athletes in the U12 and younger age groups will not be approached. However, Team Managers will be called to ensure that the uniform infringement be rectified prior to their next event. ^{'17 03 08}
- The appropriate Official will complete a uniform infringement report, which will be provided to the Uniform Manager as soon as possible prior the event being completed.
- The Uniform Manager shall contact the Announcer to call for the relevant Centre's Team Manager to report to the Uniform Manager or appointed Official(s).
- The Uniform Manager will advise the Team Manager:
 - of the athletes details and the uniform infringement e.g. bike pants rolled down from the waist, incorrect coloured shorts, compression garments only on boys, missing patch(es) or registration number and
 - that they are requested to ensure that the uniform infringement be fixed so that the athlete reports to the next event in correct uniform.
- If the infringement is due to a logo, the logo may be covered with tape at the Call Room.
- If an athlete is reported for a uniform infringement in the Call Room or on the arena for a second time, the athlete may be disqualified at the discretion of a Start / Track Referee, Field Referee, Meet Manager or Competition Manager.
- The athlete may only be approached on the arena prior to the start of event's competition or at the conclusion of the event's competition or while in the Call Room.
- After the competition, a letter will be issued to the Centre(s) whose affiliated athletes were reported of uniform infringements.
- Athletes who are reported for Uniform infringements at following LAQ competitions in the same season, may be DQ'd from competing in the competition at the discretion of a Meet Manager or Competition Manager.

4. INJURY & MEDICATION

Medical Officers are to be appointed / arranged by the Association for all Carnivals / State events, or by the Regional Competition Coordinator for Regional competitions. The appointed Officers must have appropriate first aid or medical qualifications and a Blue Card.

4.1. INJURY

4.1.1. Athletes competing with Injury

- a) An injured athlete's participation would be the sole responsibility of the athlete / parent / guardian.
- b) Any athlete with an arm cast competing on the track shall be placed in an inside or outside lane.
- c) Any athlete with an arm cast on the field would be allowed to compete, and shall not to be disqualified or excluded from competition due to the cast providing extra support. '10 05 01

4.1.2. All injuries that are sustained and / or treated during competition must be reported on the appropriate form.

4.2. MEDICATION

4.2.1. As part of its Drug policy, LAQ

- a) Is totally opposed to the use of any banned substances and use of any artificial aids for the purpose of obtaining an advantage in competition;
- b) Is totally opposed to the use of illegal recreational drugs; and
- c) Recognises that the use of caffeine (tablets, drinks or by other means) is not recommended, as it is an addictive substance and a diuretic. Athletes should be re-hydrating before and after physical activity not dehydrating.
- d) Recognises the role of Australian Sports Anti-doping Authority - ASADA in the development of policies pertaining to drugs in sport.

4.2.2. Use of Asthma Inhalers

- a) If necessary asthmatics should use their inhalers prior to each event.
- b) It is advised that inhalers be carried on the person but **MUST NOT** be held in the hand during the conduct of an event.
- c) Should an attack of asthma develop during the event, the athlete should:
 - i. Withdraw from the event immediately and may not return to the event.
 - ii. Use their medication.
 - iii. Contact their family doctor as soon as possible, advise that an attack had developed, and seek advice.
- d) Should an attack develop after the race, the athlete should follow steps as per items above.
- e) Use of inhalers is permitted while waiting at field events, but not during a trial.

5. THE COMPETITIONS

Competitions are conducted across a number of levels from Centre to National Championships.

5.1. COMPETITION LEVELS

	CENTRE	INTER-CENTRE	LAQ REGION	LAQ STATE CONDUCTED	LAA NATIONAL
Tiny Tots	Play training	Play training	Play training	Play training	====
U6	Play training Maximum of 4 events	Play training Maximum of 4 events	Play training	Play training	====
U7	Play training Individual events Relays Modified Combined Event	==== Individual events Relays Modified Combined Event	==== Individual events Relays ====	==== ==== ==== Modified Triathlon	==== ==== ==== ====
U8	Play training Individual events Relays Modified Combined Event	==== Individual events Relays Modified Combined Event	==== Individual events Relays ====	==== ==== ==== Modified Triathlon	==== ==== ==== ====
U9	Individual events Relays Modified Pentathlon	Individual events Relays Pentathlon	Individual events Relays ====	Individual events Relays Modified Tetrathlon	==== ==== ====
U10	Individual events Relays Modified Pentathlon	Individual events Relays Pentathlon	Individual events Relays ====	Individual events Relays Modified Tetrathlon	==== ==== ====
U11	Individual events Relays Modified Pentathlon	Individual events Relays Pentathlon	Individual events Relays ====	Individual events Relays Modified Tetrathlon	==== ==== ====
U12	Individual events Relays Pentathlon	Individual events Relays Pentathlon	Individual events Relays ====	Individual events Relays Pentathlon	==== ==== ====
U13	Individual events Relays Pentathlon	Individual events Relays Pentathlon	Individual events Relays ====	Individual events Relays Pentathlon	Team Competition Relays ====
U14	Individual events Relays Pentathlon	Individual events Relays Pentathlon	Individual events Relays ====	Individual events Relays Pentathlon	==== ==== ====
U15	Individual events Relays Pentathlon / Heptathlon	Individual events Relays Pentathlon / Heptathlon	Individual events Relays ====	Individual events Relays Heptathlon	==== Relays Heptathlon
U16	Individual events Relays Pentathlon / Heptathlon	Individual events Relays Pentathlon / Heptathlon	Individual events Relays ====	Individual events Relays Heptathlon	==== ==== ====
U17	Individual events Relays Pentathlon / Heptathlon	Individual events Relays Pentathlon / Heptathlon	Individual events Relays ====	Individual events Relays Heptathlon	==== ==== ====

- 5.1.1 Tiny Tots activities shall not be timed, placed or measured. All activities shall be in accordance with endorsed LAQ programs. Tiny Tots may be offered a track event to a maximum distance of 60m. '19 05 08
- 5.1.2 If offered events at Centre Carnivals, U6's can only receive participation medals. '19 05 08
- 5.1.3 Combined Events at Centre and Inter-Centre competitions may only comprise of LAQ approved events for the age groups. Such events may not exceed three (3) Combined Events for U7 & U8's, a Pentathlon for U9 - U14's or a Heptathlon for the U15 - 17's age groups. '19 05 08

5.2. COMPETITION TYPES

- 5.2.1. Centre Competition: Weekly Competition conducted in a local area. Refer to Centre Programming Manual for further detail.
- a) Centres may provide age appropriate Combined Event or Carnival type competitions, to Centre members or invited registered members of other LAQ Centres. Such competitions must be conducted under LAQ rules and comply with requirements as detailed on the LAQ Sanction Request form, which is to be completed and submitted to LAQ for consideration. Centres may also invite registered members of QA, provided their participation is sanctioned by QA. '19 05 08
- 5.2.2. Regional Competition: The State is typically divided into geographic Regions, which under the direction of the Board conduct the Regional Championships & Relays for U7 to U17 athletes; provides an opportunity for athletes to qualify for State Championship events.
- 5.2.3. LAQ State Competitions: Carnivals, State Combined Event Championships, State Relays and State Championships. '19 05 08
- 5.2.4. National Competition: The Little Athletics Australian Championships (LAAC) are held annually, for the U13 age group State Team and U15 Multi-Event Team.

5.3. LAQ CARNIVALS

- 5.3.1. The Association will arrange for a Winter Carnival, Spring Carnival & Summer Carnival for U7 to U17's.
- a) All Carnivals shall be conducted at a venue with the necessary infrastructure and an all-weather track. The Board will review the venues allocation annually.
- The Winter Carnival shall be held between April and September at a Winter Region venue,
 - The Spring Carnival shall be held within the Central Coast or North Coast Regions,
 - The Summer Carnival shall be conducted at a venue in the South East Qld Regions.
- b) The Winter and Spring Carnivals shall also be open to non-LAQ registered age appropriate athletes; and when approved, QA/ANQ registered U18 - Open athletes
- 5.3.2. The Carnivals will be run under full LAQ rules for athletes competing in the U7 to U17 LAQ events; and if events are offered for U18 - Opens, athletes will compete under agreed WORLD ATHLETICS rules (incl. uniform rules).
- 5.3.3. The Carnivals, for U7 & U8 age groups,
- a) will not have a rigid competition principle adopted. Officials can act in an advisory capacity but normal rules of competition are applied
- b) There will be no track finals and only 3 trials at any field event
- c) Protests will not be entertained
- d) Participating U7 & U8 athletes will receive a participation medallion.
- 5.3.4. Athletes nominating for the Winter Carnival
- a) U7 & U8's may nominate up to seven (7) events.
- b) U9 to U17's shall be limited to seven (7) events' with the option to compete in the 100m Handicap Race and or Track Relay if offered.
- c) U15 to U17 nominating for the Heptathlon may also nominate for two (2) individual events. *BoD 11 ('18)*
- 5.3.5. Athletes nominating for the Spring & Summer Carnival
- a) U7 to U17's shall be limited to five (5) events,
- b) Registered QA U18's - Open athletes shall be limited to five (5) events,
- c) U9 - U17's (-Open) shall have the option to compete 100m Handicap race if offered.
- 5.3.6. LAQ registered Multi-Class athletes have the opportunity to nominate in para-events or standard events; however, they may not nominate twice in the same event.
- a) QA registered U18 - Open Multi-Class athletes may have the same opportunity if approved for a specific Carnival
- 5.3.7. Track Events
- a) At the Spring and Summer Carnivals Timed Finals will be conducted. Recorded times will determine places and medals.
- b) At the Winter Carnival Heats and Finals shall be conducted for U9 - U17's where numbers warrant

- c) Relays, if conducted, will be fun events only. Therefore, there will be no placings or medals; and Best Performances will not be recognised.
- 5.3.8 In Field events at the Spring and Summer Carnival (except for High Jump), each athlete shall be allowed three trials.
- a) In High Jump, athletes will only be allowed a total of four (4) failures before being excluded from further competition in that event. Each athlete shall have three trials to clear a height. However, if an athlete misses three (3) consecutive trials they are also out of the competition.
- b) Each athlete shall be credited with the best of all his/her trials. For the U9 and higher age groups, the recorded distances will determine places and medals.
- 5.3.9. In field events at the Winter Carnival (except High Jump), for U9 - U17's in the qualifying round
- a) Where there are more than eight (8) athletes, each athlete shall be allowed three (3) trials and the eight (8) athletes with the best valid performances shall be allowed three (3) additional trials in the inverse order of ranking of their performances recorded in the first three (3) trials.
- b) If there are only eight (8) athletes or fewer in the event and one (1) or more records three (3) fouls, all athletes are entitled to proceed to the final rounds.
- c) In the event of a tie for the last qualifying place, it shall be resolved by following the count back procedure.
- d) The best overall result of the six (6) trials by an athlete will determine places and medals.
- 5.3.10. Medals shall be presented to the
- a) First three (3) place getters in each U9 to U17 event final at all Carnivals.
- b) First three (3) place getters in U15 - U17 Heptathlon at the Winter Carnival
- c) First three (3) place getters in the U18 - Open at the discretion of LAQ Competition Manager
- d) First three (3) place getters in each Multi-Class age-group category per LAQ Multi-Class specific Rules.
- 5.3.11. Each athlete will receive a certificate detailing events contested.

5.4. COMBINED EVENTS & COMBINED EVENT CHAMPIONSHIPS

- 5.4.1. For all LAQ Combined Events, athletes must compete in all set events for (and in) their (own) age group.
- a) At all Association Competitions for the U15 age group, LAQ will adopt the system in use by Little Athletics Australia for the Multi-events (Heptathlon). *JIM 11 ('09)*
- b) Any U9 - U17 athlete failing to start or make a trial, in any of the events of the Combined Event shall not be allowed to take part in the remaining events, and shall be considered to have abandoned the competition. Therefore, that athlete shall not figure in the final placings. *'88 05 01*
- c) Any athlete deciding to withdraw from the Combined Event competition shall immediately inform the Referee (through the Team Manager if prior to the commencement of the first event and directly if during the competition) of his / her decision. *'88 05 01*
- d) Where both the Combined Events and the similar individual events are offered in the same program, these should be run as separate events and programed as such.
- e) Track events: only timed finals are conducted.
- f) Field Events: three trials only.
- g) Points are awarded based on their performance.
- h) The first three (3) place getters in U9 - U17 age groups will receive medals.
- 5.4.2. LAQ U15 - U17 Heptathlon *'18 03 04*
- a) Will be offered at the Winter Carnival and the Combined Event Championships
- b) Comprises of a Hurdle event, a Sprint event, a Distance event, two (2) throws and two (2) Jumps events.
- c) Each athlete will be allocated points for their best performance in each of the seven (7) events; such points will be calculated with the WORLD ATHLETICS FAT Scoring Table for Combined Events. The calculation of points for the sprint hurdles shall be the 100m Hurdles (girls) and 110m Hurdles (boys).

d) Table of Events

Age	Day One			Day Two			
U15 Boys	100mH	Long Jump	Discus	100m	Javelin	High Jump	800m
U15 Girls	90mH	High Jump	Shot Put	200m	Javelin	Long Jump	800m
U16 Boys	100mH	Long Jump	Discus	100m	Javelin	High Jump	800m
U16 Girls	90mH	High Jump	Shot Put	200m	Javelin	Jump	800m
U17 Boys	110mH	Long Jump	Discus	100m	Javelin	High Jump	800m
U17 Girls	100mH	High Jump	Shot Put	200m	Javelin	Jump	800m

5.4.3. LAQ Combined Event Championships

a) The competition may be held in regional Queensland provided an all-weather track is available.

b) The program of events will include:

- i. U7 & U8s Triathlon 3 events: 1 track, 1 jump & 1 throw
- ii. U9 - U11s Tetrathlon 4 events: 2 track, 1 jump & 1 throw (alternating)
- iii. U12 - U14s Pentathlon 5 events: 3 track, 1 jump & 1 throw
- iv. U15 - U17s Heptathlon 7 events: per LAA standard
- v. U13 - U17s Field Jumps Multi 3 events: High, Long and Triple Jumps
- vi. U13 - U17s Field Throws Multi 3 events: Discus, Javelin and Shot '18 03 01
- vii. U13 - U17s Track Multi 3 events: 100, 200, and age relevant sprint hurdle '19 05 09
- viii. U9 - U17 MC Triathlon 3 events: 1 track, 1 jump & 1 throw '19 05 09

c) Provided the two Combined Events selected are programmed on different days, U13s & U14s may nominate for the Pentathlon and one Triathlon, or only two Triathlons; and the U15s - U17s may nominate for two Triathlons or the Heptathlon.

d) Table of Events

Age Group	Track 1	Track 2	Track 3	Jump 1	Jump 2	Throw 1	Throw 2	
U7s	100M			Long Jump		Discus		
U8s	100M			Long Jump		Shot Put		
U9 Girls	100M	800M		Long Jump		Shot Put		
U9 Boys	100M	800M		High Jump		Discus		
U10 Girls	100M	800M		High Jump		Discus		
U10 Boys	100M	800M		Long Jump		Shot Put		
U11 Girls	100M	800M		Long Jump		Shot Put		
U11 Boys	100M	800M		Long Jump		Discus		
U12 Girls	60MH	100M	800M	High Jump		Discus		
U12 Boys	60MH	100M	800M	High Jump		Shot Put		
U13 Girls	80MH	100M	800M	Long Jump		Shot Put		
U13 Boys	80MH	100M	800M	High Jump		Discus		
U14 Girls	80MH	100M	800M	High Jump		Shot Put		
U14 Boys	90MH	100M	800M	High Jump		Shot Put		
U15 Girls	90MH	200M	800M	Long Jump	High Jump	Shot Put	Javelin	
U15 Boys	100MH	100M	800M	Long Jump	High Jump	Discus	Javelin	
U16 Girls	90MH	200M	800M	Long Jump	High Jump	Shot Put	Javelin	
U16 Boys	100MH	100M	800M	Long Jump	High Jump	Discus	Javelin	
U17 Girls	100MH	200M	800M	Long Jump	High Jump	Shot Put	Javelin	
U17 Boys	110MH	100M	800M	Long Jump	High Jump	Discus	Javelin	
		Jumps Combined Event					Throws Combined Event	
U13-U17s	High Jump	Long Jump	Triple Jump	U13-U17s	Discus	Javelin	Shot Put	
		Track Combined Event						Multi-Class Combined
U13-U17s	100m	200m	Hurdle	U9-U17sMC	100m	Long Jump	Discus	

5.5. THE RELAYS

- 5.5.1. For the Regional Relays, the host venue should have a 400m track. The location of the Regional Relays shall be determined on a rotational basis or as determined by the Regional Committee.
- 5.5.2. LAQ Regional and State Relay programs shall offer two Track Relay events per age group, namely:
- U9 & U10s: 4 x 100m and 4 x 200m circular in lanes
 - U11 & U12s: 4 x 100m and 4 x Swedish (1 each 100m, 300m, 200m & 400m)
 - U13 & U14's; 4 x 100m and 4 x Medley (2 x 200m, 1 x 400m, 1 x 800m)
 - U15 - U17's: 4 x 100m and 4 x Swedish (1 each 100m, 300m, 200m & 400m) *BoD 10 ('18)*
- 5.5.2. Athletes in the U7 and U8 age groups may only compete at Regional level.
- The only events that may be provided for the U7 age group are 4x70m and 4x100m, Long Jump and Discus
 - The only events that may be provided for the U8 age group are 4x70m, 4x100m, Long Jump and Shot Put
 - The actual events to be provided from those listed above, shall be decided by the Regional Competition Committee and may vary from one Region to another
 - A maximum number of three trials shall be allowed for field events *18' 02 03*
- 5.5.3. There is no limit on the number of teams per Centre.
- 5.5.4. Athletes may not nominate or substitute in track events, throwing events and high jump where the events specifications exceed their age group standard events and specifications as detailed in the LAQ Competition Handbook. *BoD 6 ('18)*
- 5.5.5. Every effort must be made to ensure all athletes compete in their own age group, however if this is not possible refer to the following rules.
- 5.5.6. All Centres are to supply the Regional Competition Recorder with the following, as at close of nominations, prior to the commencement of the Competition or at an agreed date set by the Region.
- a list of athletes,
 - their respective events,
 - the athletes' best performances as at close of nominations. *'09 04 02*
- Subsequent track team alterations are to be advised prior to the start of competition, where possible and throughout the Regional Relay competition day. This rule also applies to reconvened days due to cancellation.
- 5.5.7. Track & Field Team Composition / Nomination
- Relay teams For Regional and State Relays, track event teams are made up of four (4) athletes.
 - For Regional Relays track events, at least four (4) athlete names are required when nominating each team.
 - For Regional Relays, field event teams are made up of the number of nominated athletes.
 - For State Relays, the two (2) top qualifying athletes from the same Centre, or a Multi Centre team shall form a field event team, and so on (i.e. 1st and 2nd top qualifying athletes shall form Team A; 3rd and 4th top qualifying athletes shall form Team B etc.).
 - Athletes may compete in both track and field events, however may only nominate for a maximum of five (5) events. Athletes may participate in six (6) events if that athlete is used as a substitute athlete on the day of competition. This excludes any run-off events that the Region conducts to select the U15 & U17 Regional Relay teams.
 - No athlete is able to compete in another age group/gender to suit his or her individual needs (e.g. timing of program of relevant event, availability, or inability to attend the whole day).
 - There can only be ONE (1) Combined age group team per event, per Centre. Athletes competing in "Combined" teams are eligible to compete in that event at the State Relay Day, should they qualify.
 - At Regional Relays, should an athlete from a younger age group be nominated to compete up, but the athlete he/she is partnering withdraws from the competition after the closing date or does not compete on the day of competition, the athlete may withdraw from these events and then be included in an equivalent number of field events in their own age group. *19' 05 08*

- ii. Combined Teams can be made up of:
 - o Boys and Girls; teams having both boys and girls are classed as 'boys' teams.
 - o Mixed ages.
 - o A combination of i & ii, from one (1) Centre.

In such a team, there must be at least one athlete who is a member of that age group.

It should be noted that Meet Manager reference Boys teams as mixed, this term should not be confused with 'Combined teams' as indicate in the above rules.

BoD 16 ('14)

- h) At Regional Relays, athletes may not nominate to compete in the same event for more than one (1) age group or team. *AR 17 ('12)*
- i) When there is only one (1) athlete nominated in a field event for Regional Relays, the following options (subject to existing rule) are available, so that the athletes/s may be recorded as a team:
 - i. A girl may be nominated / compete as a boy,
 - ii. An athlete may be nominated to compete up, or
 - iii. An athlete from a younger age group may be nominated / compete up.
- j) For the purpose of making up a team, U7 to U12 athletes may be nominated to compete in older age group Relays to a maximum increment of two (2) age groups. U13 and older athletes may be nominated to compete in older age group Relays to a maximum of three (3) age groups. However, *BoD 7 ('18)*
 - i. The best athlete from a lower age group must not be placed in an older age group team with the best athlete(s) of that age group, except in the case where only one (1) athlete for field events/or three (3) athletes for track events exists in that higher age group.
 - ii. At Region and State Relay competitions only; U16 Boys shall be allowed to throw the same implement weight used in Discus and Shot Put as the U17 Boys; in order to make up a team when nominating or substituting as U17 Boys team. *BoD 6 ('16)*

5.5.8. Substitutions

- a) In the case of an athlete being absent on the day of competition, any other nominated athlete may participate as a substitute for their Centre for any age group team; provided that all rules are applied. When competing as a substitute athlete, the athlete must not compete twice in the same event for the same age group.
- b) In the case of an athlete being absent on the day of competition, an U7 or U8 athlete may participate as a substitute athlete for an U9 team at the Regional Relays. However, the athlete from the U7 or U8 age group cannot participate at the State Relays if the team qualifies. The U7 or U8 may only be replaced by an U9 athlete who competed at the Regional Relays.
- c) In the case of an athlete being absent on the day of competition, an athlete from the same Centre can come up from a lower age group and do that same event again to allow the remaining three (3) athletes to run a track relay, giving this athlete a maximum of six (6) events if he / she is prepared to run the event twice. *BoD 8 ('18)*
- d) If an athlete is absent in an age group on the day of competition, an athlete from the same Centre can come up from a lower age group and compete in that event to allow the remaining athlete to compete in the field event relay, giving this athlete a maximum of six (6) events if he / she is prepared to contest the event (possibly twice), and the sole remaining athlete an opportunity to qualify as a team for State Relays. *BoD 8 ('18)*
- e) If an athlete competes at the Regional Relays as a substitute in a sixth event and qualifies for six (6) events, he or she shall be able to nominate for State Relays in those six (6) events. *'15 02 02*
- f) At State Relays, where a Centre has two (2) or more teams competing in an event; and an athlete withdraws from a higher ranked team, the Centre may only use a member from the next lowest ranked team as a substitute. The losing lower ranked team(s) may then use one (1) of the Centres reserves, if all other rules are adhered to. *'10 09 01*
- g) At State Relays, an athlete may compete as a substitute for their Centre for any age group team, provided that all rules are applied. However, such athletes must have competed at the Regional Relays.
- h) Absent on the day also includes injuries that occur during Competition, rendering an athlete unable to compete for the rest of that Competition. *BoD 19 ('12)*

5.5.9. Composite Teams comprise of athletes from more than one (1) Centre. So formed on the day of competition, are NOT ELIGIBLE to compete in that event at the State Relay Day. Composite teams should be distributed evenly through the heats.

- 5.5.10. Nominated Multi Centre teams may be formed by small Centres (less than 75 registered U9 - U17 athletes) and nominated by the nomination closing dates. Such teams shall be eligible to compete in the events at the State Relays day. BLI 8 ('16)
- a) The Small Centres (less than 75 registered U9 - U17 athletes) will be identified and notified at the commencement of the summer season, but based on the final registrations of the previous season. Allowances will be made for Centres not identified as small Centres to "appeal their status" to the Association should Centre registrations alter dramatically from one season to the next. MAR 15 ('19)
 - b) The Regional Coordinators and all Centres within each Region will be notified of the eligible Centres from their Region under the Small Centre rule.
 - c) Eligible Small Centres may negotiate the composition of the teams amongst themselves.
 - d) All substitution rules can be applied by Multi-Centre Teams (nominated track teams and / or field entrants) using athletes from small Centre within the same Region. '18 05 02
 - e) In the U15-U17 age groups, Small Centres may form Multi Centre teams from athletes from any Centre in the Region if athletes in that age group are not available from the other Small Centres in the Region. Combinations between a small Centre and a non-small Centre must be approved by LAQ, based on submissions prior to the close of nominations. MAR 16 ('19)
 - f) Track Events
 - i. Small Centres must make eligible track teams up from their own Centre before nominating athletes for inclusion in Multi-Centre Teams.
 - ii. Where there are more than four nominated athletes in a particular age group from an eligible Centre, those athletes not included in the Centre team are eligible to be nominated in a Multi-Centre team. The best athletes must first be used in the Centre team, and not allocated to the Multi-Centre Team.
 - iii. An athlete cannot be nominated to compete in the same track event for more than one age group or team.
 - g) Field Events
 - i. Small Centres will nominate athletes individually for each field event.
 - ii. Where there are two or more nominated athletes from the one Small Centre in a particular age group, the two highest placed athletes from the one Centre at the Regional Relays must form a team and the next two highest placed athletes from the same Centre must form a team and so on. Athletes from eligible Small Centres who are unable to be included in a Centre team are eligible to be included in a Multi-Centre team. The Multi-Centre teams shall be formed in order from the two highest placed eligible athletes followed by the next two highest placed eligible athletes and so on.
 - iii. If, at the close of nominations there is only one athlete nominated in total in a particular field event from all of the eligible Small Centres, the nominating Small Centre may bring up an athlete from their own Centre from a younger age group or bring a girl into a boys team, provided the implement weight, if it is a throwing event, is not higher than the permitted weight for the substituting athlete.
- 5.5.11. Teams Qualifying for the State Relays
- a) Athletes in the U9 to U17 age groups may qualify from Regional Relays.
 - b) U7 & U8's must not compete at State Relays in older age group teams.
 - c) A maximum of **three (3)** track teams may proceed through to the State Relays. Progression is based on times only.
 - d) Regional Field Teams
 - i. Only a maximum of **three (3)** teams may proceed through to the State Relays, from each applicable age group, from each Region.
 - ii. A count back is to be used to split equal placed field teams/athletes, for State Relay qualification.
 - iii. In the event a count back does not split teams, reference would be made to the Centre Best Performances; if a tie still remains, then the progressing teams shall be decided on the flip of a coin.
 - iv. If there are two (2) or more athletes from the same Centre and only one athlete has recorded a distance / height, the second athletes will be selected based on their Centre Best Performance.
 - e) Must not be changed, except in cases of illness or absence on the day.
 - f) To ensure that all members of qualifying teams from Regions are guaranteed their positions at State Relays, their individual names **MUST** be recorded at the Regional Relays.
 - g) Should a qualifying relay team be withdrawn from State Relays, there shall be no replacements teams.

- h) No entry fee to be charged for Relay Teams that withdraw before the prescribed closing date for State Relays. *CAB 1 ('93)*
- i) It is the Centre's responsibility, if they wish to do so, to allow for certain reserves (who have competed at Regional Relays) to be available for the State Relay Day to fill in for a team in case of illness etc.

5.5.12. The State Relays are held in December each year for track and field teams: Four (4) athletes per track team and two (2) athletes per field team.

- a) Centres from Central Coast, Tropical North, North Qld, Central North and Maranoa Regions may nominate teams for direct entry into the State Relay Championships. The team must meet the guidelines set down by the Association. Nominations must be received at the Association office, accompanied by the appropriate fees, by 4:00 pm on the closing day specified in the Competition Calendar (page 3). If more than three (3) teams from one (1) Region are nominated in a specific event, the teams with the best three aggregate Centre performances will progress to the State Relay Championships. *BoD 18 ('14)*

- b) Medals will be awarded to the first three placed teams in each event after all countback procedures have been applied. *IPS 11 ('15)*

- c) Each Region may enter U15 4 x 100m Regional Relay Teams, one (1) boy's team and one (1) girl's team to compete at the State Relay Championships. Only U15's may compete in this event. Place getters in this event will be presented with medals in recognition of their efforts.

Where there are more than four athletes expressing interest for team selection, Regions are to conduct a 100m race-off between interested athletes to select the team(s). *BoD 19 ('14)*

Regions are to conduct a 100m race off between interested athletes to select the team(s).

- d) Each Region may enter U17 4 x 100m Regional Relay Teams, one (1) boy's team and one (1) girl's team to compete at the State Relay Championships. Only U16 and U17's may compete in this event. Under 16 athletes can only compete in this event if there are not enough U17 athletes to fill the team. Place getters in this event will be presented with medals in recognition of their efforts.

Where there are more than four Under 17 athletes expressing interest for team selection, Regions are to conduct a 100m race-off between interested athletes to select the team(s).

If there are not enough Under 17 athletes to fill the team, a race-off will be conducted with the Under 16 athletes to fill the team. *IPS 9 ('18)*

5.5.13. Track Relay Rules & Procedures

- a) There will be NO finals.
- b) The 4 x 100m circular and the 4 x 200m circular relays are run entirely in lanes. *'19 10 08*
- c) The running order of the Swedish Relays shall be 100m 300m, 200m and 400m. The Swedish Relay is run in lanes by the first runner, with the 2nd running part of their section (leg) in their designated lane, cutting across at the dedicated markers in the front straight. The 3rd runner shall be placed on the track, by the designated official from inside to outside at the 200m start point, in the order that the 2nd runner passes the finish line. The 4th runner shall be placed on the track by the designated official, from inside to outside at the 400m start point, in the order that the team completes the second leg. *'19 05 08*
- d) The order of running the 4 x Medley Relay shall be 200m, 200m, 400m, and 800m. *'19 10 08*
 - i. The Medley Relays are run in lanes by the first two runners, with the third runner running part of the section (leg) in their designated lane. *'19 10 08*
 - ii. The 4 x Medley the 4th runner shall be placed on the track, by the designated Official, in the same order inside to outside on the track as their respective team member completes the first 200m of their leg.
 - iii. Waiting athletes shall maintain their order and shall not exchange positions at the beginning of the take-over zone.
- e) Athletes waiting for the changeover may move in as the athletes closest to the inside dispatch, as long as the order is maintained and there is no interference. Refer to WORLD ATHLETICS rules for specific detail.
- f) In all Relays there are no acceleration zones and all athletes shall begin running from within their take-over zones.
- g) In all of the Track Relay races, all athletes at all changes other than the first athlete will be initially placed inside the takeover zone by the designated Official.
- h) The passing of the baton commences when it is first touched by the receiving runner and is completed at the moment it is in the hand of the receiving runner only. Within the take-over zone, it is only the position of the baton that is decisive and not the position of the body or the limbs of the athlete.
- i) The baton must be carried by hand throughout the race.

- j) If dropped, the athlete who dropped it must recover the baton. The athlete may leave their lane to retrieve the baton. Provided this procedure is adopted and no other athlete is impeded, dropping the baton shall not result in disqualification.
- k) Athletes after handing over the baton should remain in their lanes until the course is clear or when advised by the change umpire.
- l) When a relay race is being run in lanes, an athlete may place a check-mark on the track within their own lane, e.g. using adhesive tape (max 5cm x 40cm), but may not place marking objects on or alongside the track.
- m) Should any athlete willfully impede a member of another team by running out of their lane at the finish of their stage they are liable to cause the disqualification of their team.
- n) No athlete may run more than one (1) section (leg) for a team.

5.5.14. Field Relay Rules & Procedures

- a) Long Jump, Shot Put & Discus: three (3) trials per athlete. If however, the Chief Judge sees fit, there will be two (2) trials per athlete.
- b) In High Jump, there will be two (2) trials only per athlete per height.
- c) At the Regional Relays, athletes competing on their own would not be eligible to qualify for State Relay Championships or be considered as a place getter at Regional Relays.
- d) At Regional Relays, the order of team placings in an event will be determined by the pairing of the best-ranked athletes and the addition of their best performances in each Centre team. This will give a team of two a total distance achieved, thereby placing the teams for qualification to the State Relays.
- e) At Regional and State Relays athletes competing in the High Jump may continue to compete even when or if one (1) member of the team does not clear the starting height. *BoD 5 ('19)*
- f) At the State Relays, the order of team placings in an event will be determined by the addition of each athlete's best performance in each team, which will give the team a total distance achieved.

5.6. REGIONAL & STATE CHAMPIONSHIPS

- 5.6.1. For Summer Regions, U7 to U17 athletes are allowed to nominate for a maximum of five (5) events for the Regional Championships.
- 5.6.2. For Winter Regions, U9 to U17 athletes are allowed to nominate for a maximum of seven (7) events; and U7 & U8 are allowed to nominate for a maximum of five (5) events.
- 5.6.3. At the LAQ Regional Championships, participation medallions will be provided for all competing U7 & U8 athletes. *BOM C39 ('03)*
- 5.6.4. At the LAQ Regional Championships, athletes in the U9 to U17 age group who place first, second or third in the finals will be awarded medals for that event. *BOM C40 ('03)*
- 5.6.5. One certificate per athlete showing results for all events including finals will be issued for Regional Championships and State Championships competitions. *IPS 44 ('04)*
- 5.6.6. Athletes in the U7 & U8 age groups may only compete at Regional level,
 - a) Events that will be provided for the U7 age group are taken from the following: 70m, 100m, 200m, Long Jump, Discus, and Shot Put.
 - b) In addition to the above, 60m Hurdles may be programmed for the U8 age group.
 - c) The actual events to be provided will be decided by the Regional Competition Committee and may vary from one (1) Region to another.
 - d) Track Events: Finals will not be conducted (heats only)
 - e) Field Events: Three (3) trials only (no final eight (8)).
- 5.6.7. The location of Regional Championships within a Region to be determined on a rotational basis or as determined by the Regional Committee. *BoD 6 ('17)*
- 5.6.8. The Centre hosting Regional Championships is allowed to host it at grounds that have synthetic surfaces, if the majority of the Centres in that Region approve. *BLI 52 ('99)*
- 5.6.9. Should a Region wish to conduct these events on a synthetic surface, the cost of hire of the venue must be borne by the Region and not passed on to the athletes or their families. The Association will not be responsible for any shortfall in funds incurred by hiring such a venue.
- 5.6.10. For State Championships, only athletes in the U9 to U17 age groups may qualify for the State Championships from Regional Championships. All qualifying athletes can only nominate in a maximum of five (5) events.

- 5.6.11. State Championships are conducted at the end of the Competition season (generally late March or early April) each year.
- 5.6.12. State Championships are to be held in a venue in the Winter Centre’s Region every fourth year, as long as an all-weather track of suitable standard is available. BUND 21 (‘05)
- 5.6.13. From State Championships finals, medals are presented to the first three (3) place getters in the U9 to U17 age groups. WB 18 (‘13)
- 5.6.14. At the LAQ State Championships, classified Multi-Class (athletes with disabilities) are accepted to compete in limited events under their own classification up to State level as determine by the Competition Committee. WB 18 (‘13)
- 5.6.15. Classified Multi-Class athletes placings will be calculated in age groups U9 & U10’s, U11 & U12’s, U13 & U14’s, and U15 - U17’s; and based on a percentage calculation across Multi-Class classifications. ‘16 09 14

5.7. LITTLE ATHLETICS AUSTRALIAN CHAMPIONSHIP

- 5.9.1. The Competition is held over two (2) days on a rotational basis throughout the States. The team is comprised of an U13 team - normally 13 boys and 13 girls. Two (2) athletes are selected for each event and one (1) team selected for each relay. There is also an U15 team, which is limited to six (6) athletes (three boys and three girls) and they compete in the Multi-Event. Selection in the Queensland State Team is based on performances at the LAQ State Championships. Refer to the LAQ State Team Booklet for further information. AT12 (‘04)

6. ELIGIBILITY / NOMINATION

6.1. ELIGIBILITY

- 6.1.1. All athletes must be registered with LAQ, or in specified circumstances QA, unless by specific invitation of the Association.
- 6.1.2. Age of the Athlete is calculated as at midnight on the 31st December each year.
- 6.1.3. Athletes can only compete in their own age group. THE ONLY EXCEPTION TO THIS RULE IS MADE ON RELAY DAYS - refer to the specific Relay rules.
- 6.1.4. That eligibility for nomination to Regional Championships and State Championships include a requirement of prior participation in not less than four (4) Centre level meetings at the Centre where the athlete is registered, unless the committee of management of the nominating Centre considers that extenuating circumstances exist. C29 (‘87)
- 6.1.5. LAQ offer various levels of competition to U9 - U17 Classified athletes - refer to the LAQ Multi-Class Competition Handbook for complete details.
 - a) Multi-Class athletes must participate at Regional Championships to be eligible to lodge a direct nomination for participation in Multi Class events offered at the State Championships in the same season. Placing at the Regional Championships is not a prerequisite for qualification in Multi Class events. ‘19 10 08
 - b) Events offered for boys & girls at LAQ Carnivals and Regional and State Championships unless otherwise stated. ‘20 07 14

EVENTS	U9 & U10	U9 & U10 Wheelchair	U11 & U12	U11 & U12 Wheelchair	U13 & U14	U13 & U14 Wheelchair	U15 – U17	U15 – U17 Wheelchair
100m	✓	✓	✓	✓	✓	✓	✓	✓
200m	✓	✓	✓	✓	✓	✓	✓	✓
400m	✓	✓	✓	✓	✓		✓	
800m	✓	✓	✓	✓	✓	✓	✓	✓
Long Jump	✓		✓		✓		✓	
Discus	✓		✓		✓		✓	
Shot Put	✓	✓	✓	✓	✓	✓	✓	✓
Javelin			✓		✓		✓	

6.2. NOMINATION

- 6.2.1. All nominations must be received by the published Competition closing date. Nominations fees and summary of nominations form must be paid and or received by the nominated closing date for that specific event by the LAQ Office. Cheque must be made payable to Little Athletics Queensland.
- 6.2.2. Nominations lodged online through ResultsHQ are the only recognised form of electronic nominations. All other formats are considered to be hard copy. '19 05 08
- 6.2.3. Regional Competition nominations must be provided to the Association Office by the required date and time. '19 05 08
- 6.2.4. For each Regional Competition, Centres that do not use either of the systems detailed above to supply nominations will be charged a \$50.00 administration fee per Competition, as well as \$1.00 per athlete nomination. Centres cannot pass this fee onto its athletes or parents; it is an administration fee ONLY.

6.3. LATE NOMINATION

- 6.3.1. Late nominations will be accepted for the Carnivals and the State Combined Event Championships until 4:00pm on the Thursday before the respective competition days, unless special circumstances warrant approval by the Association CEO. BoD 12 ('12)
- 6.3.2. Nominations **will not** be accepted on the day of any LAQ Competition or Championships. '20 03 10
- 6.3.3. Late nominations fee is double the nomination fee. BoM 48 ('99)
- 6.3.4. If the Association Office receives nominations from a Centre after the closing date, apart from the appropriate nomination fee, the Centre will also be charged a Late Administration Fee of \$55.00. (incl. GST). Such nominations will not be accepted after the Wednesday prior to the competition. '20 03 10
- 6.3.5. No late nominations will be accepted for Regional Competition days, after the date set by the Region for all Centre nominations to be received. MTG 26 ('96)
- 6.3.6. No late nominations will be accepted for the State Relays or the State Championships. BoD 13 ('12)

6.4. QUALIFICATION TO STATE CHAMPIONSHIP EVENTS

- 6.4.1. U7 and U8's do not progress beyond Regional Championships. BoD 14 ('09)
- 6.4.2. The number of qualifying U9 to U17 athletes that may nominate from Regional Relays to State Relays teams will be the first three (3) place getters teams in each event. BoD 13 ('09)
- 6.4.3. The number of qualifying U9 to U17 athletes that may nominate from each of the Summer Regional Championships to State Championships will be the first four (4) place getters in each event. BoD 13 ('09)
- 6.4.5. Athletes in the Winter Region Centres who have placed 1st, 2nd, or 3rd at Regional Championships; and who have also qualified in other events to compete at the State Championships, can drop one (1) of the events in which they placed, for another in which they have gained a qualifying standard.
- 6.4.6. There is a time limit to be met for athletes to be eligible to compete at State Championships for the 1500m run. Athletes who have not equaled or bettered the qualifying time of 7 minutes at Regional Championships, irrespective of placing, shall not proceed to State Championships. BoD 3 ('15)
- 6.4.7. A count back is to be used to split equal placed field athletes, for State Championship qualification. In the event a count back does not split the athletes, Best Performances from Centre level and any Association Competition Day with the exception of Relay days shall be used at the time of nomination. '20 03 10
- 6.4.8. An athlete and or team that choose not to compete at a State Championship event after qualifying at Regional level may not be replaced by another athlete / team.
- 6.4.9. Additional Entry to State Championships
- a) Under Compassionate Grounds: For additional entry into State Championships (other than on medical grounds), recommendations will be considered on compassionate grounds only, as determined by the Board of Directors. Recommendation to come from the Centre to the CEO who will then take recommendations to the Board for decision.
 - i. A fee of \$55 (incl. GST) must accompany all compassionate grounds applications for State Championships when lodged. This fee will only be refunded if the application/s are accepted.

- b) Via Qualifying Performance Levels: Athletes who compete at the Regional Championships and record a legal distance, time or height equal to or better than a "Qualifying Performance Levels" for that event shall also qualify for the State Championships in addition to athletes placed 1st, 2nd, 3rd or 4th in that event.
Refer to the LAQ Website for Additional Qualifying Performance Levels. *BoD 6 ('19)*
- c) Medical applications for participation in the State Championships will not be considered. *BoD 17 ('13)*

7. COMPETITION RULES

7.1. GENERAL

- 7.1.1. The rules in this handbook set down the requirements for competition for all Carnivals conducted on behalf of the Association. All Carnivals are to be conducted under the rules set down in the World Athletics Handbook, or as otherwise stated in this Handbook and or the Officials' Handbook.
- 7.1.2. The Association will not adopt any changes to specifications of events or changes to events during the competition season. *W5 ('93)*
- 7.1.3. Decisions made at Conference, which affect the general aspect of competition, excluding changes as specified in Rule 7.1.2, shall come into effect immediately. *BoD 7 ('12)*
- 7.1.4. That any competition motion passed by Conference shall not be rescinded within two years unless 80% of those eligible to vote are in favour. *C1 ('86)*
- 7.1.5. At all Association competitions, no athlete shall be charged an additional nomination fee by a Centre or Region. The total nomination fee charged shall be the fee as set by the Association. *'10 03 01*
- 7.1.6. Awarding of prize money is not permitted at any level of LAQ competition (including Centre).
- 7.1.7. The immediate area of competition is to be clearly marked or instructions as to what is considered the immediate area should be clearly given prior to the commencement of the event.
- 7.1.8. Only athletes and Officials are permitted on the competition area. Athletes must leave the arena immediately after the completion of their event. No unauthorised persons are to be in the competition or Control Room AT ANY TIME. If this rule is breached the relevant athlete(s) may be disqualified.
- 7.1.9. Coaching of participating athletes from INSIDE the competition arena is NOT permitted and may cause disqualification of the athlete.
- 7.1.10. Event block starting times shown, in the LAQ Regional, Carnival and Championship programs may be brought forward no more than 30 minutes. The Meeting Manager may change the start times at his discretion after consultation with the relevant Referees. Athletes should be in attendance 60 minutes prior to the advertised event block start time. *'20 03 10*
- 7.1.11. Centres are not to use two-way radios that interfere with event communications during Association conducted competitions. *'19 05 08*
- 7.1.12. Athletes are not allowed the use of electronic communications or similar devices on the competition arena. *'19 05 08*
- 7.1.13. Athletes may warm up with provided Association equipment. Athletes must be under the supervision of an adult /coach and all equipment taken for warm-ups must be signed for and returned within an agreed timeframe. *'11 04 13*

7.2. PROGRESSION TO THE NEXT ROUND / FINAL

- 7.2.1. In track events, at all Association competition days, the progression of athletes from heats to finals where 8 lanes are available for the 70m, 100m, 200m, 400m; Sprint & 200m Hurdles events, will be as follows:
- Two Heats: 1st, 2nd & 3rd and next two (2) best times to final
 - Three Heats: 1st & 2nd from each heat and the next two (2) best times to final
 - Four Heats: 1st from each heat and the next four (4) best times to final.
 - Five Heats: 1st from each heat and the next three (3) best times to final. *CR5 ('92)*
- 7.2.2. In the event of tied 'next fastest' times, preference in the selection of finalists will go to those more highly placed in their heats. If runners cannot be separated on this basis, a ballot may be conducted to determine the 'next fastest' finalists.

- 7.2.3. To compete in a final where heats are included in the program, athletes must have qualified in heats; or, in the case where heats are no longer necessary, the athletes must have presented themselves for the heat and had their name marked off by the Chief Call Room Judge.
- 7.2.4. There will be a maximum of eight (8) finalists only in all track and field events (except for the 800m, 1500m and Walk events) at the Winter Carnival, and the Regional and State Championships, except in the case of a tie or an appeal.
- a) For track events, if the number of athletes nominated or marshalled is less than or equal to the number of lanes available, then that event is run as a straight final at heat time, up to a maximum of 10 athletes. *BoD 7 ('19)*
- 7.2.5. At Regional and or at State Championships, if there are insufficient athletes for heats in any event at the time of seeding, the event will be run as a final at the time of the heat. *BoD 15 ('13)*
- 7.2.6. In field events (except High Jump), in the qualifying rounds at Regional and State Championships and the Winter Carnival
- a) Where there are more than eight (8) athletes, each athlete shall be allowed three (3) trials and the eight (8) athletes with the best valid performances shall be allowed three (3) additional trials in the inverse order of ranking of their performances recorded in the first three (3) trials.
- b) If there are only eight (8) athletes or fewer in the event and one (1) or more records three (3) fouls, all athletes are entitled to proceed to the final rounds.
- c) In the event of a tie for the last qualifying place, it shall be resolved by following the count back procedure.
- d) The best overall result of the six (6) trials by an athlete will determine his place.

7.3. CALL ROOM (Marshalling)

- 7.3.1. At Association Carnivals and or Championship events, athletes competing in track events are to marshal in the designated areas before entering the competition arena for events. Athletes are to marshal directly to the relevant field events as soon as possible once the Call has been made. Athletes competing at the Regional competitions are to marshal at the Regions' designated areas. *BoD 1 ('15)*
- a) The Call for athletes to report to FIELD events will be made approximately 20 minutes before the event start time to allow for registration and warm-up.
- b) The Call for athletes to report to CALL ROOM (marshalling area) for all track events up to 400m will be made approximately 20 minutes before the event start time.
- c) The Call for non-laned events e.g. 800m, 1500m, Relays and Walks will be made approximately 25 minutes before the event start time. This is to allow the placement of hip numbers on the athletes.
- d) Once athletes have left Call Room, any athlete who has not reported to Call Room will be declared a non-starter in that event. *'19 05 08*

7.4. TRACK EVENTS

- 7.4.1. Electronic timing and photo-finish facilities shall be used at all Association Carnivals where available (Summer & Spring Carnivals, Combined Event Championships, State Relays and State Championships and the Winter Carnival). *MTG 56 ('99)*
- 7.4.2. Timing gates that are a commercially available product shall be recognised and endorsed as an electronic timing device suitable for Regional and Centre competitions. *BoD 12 ('14)*
- 7.4.3. Seeding / Lane draws shall be as follows
- a) Summer and Spring Carnivals - provided that Centre Best performances are supplied, athletes nominated for track events will be seeded slowest to fastest. Heats and lanes will be drawn randomly.
- b) Combined Event Championships - will be by random draw. The 800m lane draw, will be based on points leading into that event.
- c) State Relays - from the Regional Relays performances supplied, the track teams and heats will be seeded slowest to fastest. Lanes are then drawn randomly.
- d) State and Regional Championships, and the Winter Carnival- Heats will be seeded, lanes will be drawn randomly. Where there have been qualifying heats, athletes shall be split drawn for lanes in finals i.e. fastest four (4) randomly in the lanes 3, 4, 5 & 6; the remainder of the field shall be drawn randomly. Lane draws for finals will be posted prior to the event.

- e) In the event that the State Championships is affected by weather or other unforeseen circumstances, and heats become "timed finals", the athletes nominated for track events will be reseeded slowest to fastest. Lanes will be drawn randomly.
 - i. The application of the above rules shall only be applied to events where no heats of the same age group have been conducted. *JIM 6 ('15)*
- f) A waterfall start shall be used for all 1500m and Race Walking events; that is seeded fastest to slowest with the fastest athletes on the inside lanes, the slowest athletes on the outside lanes. *'10 05 02*
- g) A separate lane shall be provided for each athlete in all races up to and including 400m.
- h) Where there are fewer athletes in a laned heat/final than the number of lanes available, lane one (1) should be left vacant.

7.4.4. The maximum number of athletes in 800m timed finals at LAQ's Regional and State Championships, the Combined Event Championships, Carnivals, will be two per lane (e.g. sixteen on an eight (8) lane track, eighteen on a nine (9) lane track and twenty on a ten (10) lane track).

- a) Where more than one timed final is required, the athletes will be seeded from slowest to fastest so that the fastest qualifiers will be in the same race *BoD 2 ('15)*
 - i. Athletes will be divided evenly between heats
 - ii. The fastest seeded heat will be conducted last. *'19 05 08*
- b) Where there are fewer athletes in the race than available lanes, each athlete will start from a separate lane.

7.4.5. For the 1500m Run and all Race Walk events, the maximum number of athletes allowed per race is normally 24 (for tracks having up to 8 lanes), but up to 30 are allowed for tracks having 10 lanes.

- a) At the Combined Event Championships, Spring and Summer Carnivals, staggered starts will be conducted allowing up to 40 athletes per race at the discretion of the Competition Manager.
- b) If there are more athletes than are allowed in a single race, then multiple seeded races will be conducted as timed finals.
- c) The Competition Manager may combine events into one race, provided the total number of athletes does not exceed 24 for 8 lanes and 30 for 10 lanes. *BoD 13 ('14)*

7.4.6. A crouch Start may only be used by U11 - U17 athletes for track events up to and including the 400m event. *'15 08 11*

- a) A Three Point Start is not a recognised start, and shall not be allowed / used at any LAQ competition. *'19 05 08*

7.4.7. At Association Carnivals, Combined Event Championships, Regional and State Championships, starts for 800m finals shall be run in lanes as far as the nearer edge of the marked break line after the first bend. *BoD 9 ('12)*

7.4.8. Pack starts are used for 1500m and all Walk events at Association Competitions and Centre Competitions.

7.4.9. In all races run in lanes, each athlete shall keep within their allotted lane at all times.

However,

- a) If an athlete is pushed or forced by another person to run outside his lane and no material advantage is gained;
 - b) Runs outside his lane in the straight and no other runner is obstructed;
 - c) Runs outside the outer line of his lane on the bend, with no material advantage thereby being gained, and no other runner being obstructed,
- then the athlete should not be disqualified.

Apart from the above three (3) exceptions, if the Referee is satisfied, on the report of a judge or umpire or otherwise that an athlete has run outside his lane, the athlete may be disqualified.

7.5. WALKS

Race Walking is a progression of steps so taken that the walker makes contact with the ground, so that no visible (to the human eye) loss of contact occurs. The advancing leg shall be straightened (i.e. not bent at the knee) from the moment of first contact with the ground until the vertical upright position.

Note: The advancing foot of the walker must make contact with the ground before the rear foot leaves the ground.

- 7.5.1. There is a time limit to be met for athletes to be eligible to compete at State Championships for all Race Walking events. Athletes who have not equalled or bettered the following times at Regional Championships, irrespective of placing, shall not proceed to State Championships. Time limits are
- a) 7 minutes for the 700m Walk
 - b) 9 minutes for the 1100m Walk
 - c) 12 minutes for the 1500m Walk (U12 & U13's)
 - d) 10 minutes for the 1500m Walk (U14 to U17's)
- ASP 4 ('15)*
- Athletes shall be awarded time, place and medals at Regional Championships irrespective of time recorded, unless DQ under the Walks rules.
- 7.5.2. Time restrictions shall be applied for Walk events conducted at the State Championships and are as follows:
- a) 7 minutes for the 700m Walk
 - b) 9 minutes for the 1100m Walk
 - c) 12 minutes for the 1500m Walk (U12 & U13's)
 - d) 10 minutes for the 1500m Walk (U14 to U17's)
- The race timing will cease when the above times have been reached and the athlete/s who have not finished the race shall be removed from the track. A DNF will be recorded as their result. Athletes on the front straight when timing ceases will not be removed from the track. *BoD 10 ('19)*
- 7.5.3. There is a time limit of 20 minutes for the U14 - U17's 3000m Walk event conducted at the Summer & Winter Carnival. *'10 09 02*
- a) The timing of the race will cease when the above time has been reached and the athlete/s who have not finished the race shall be removed from the track. A DNF will be recorded as their result. Athletes on the front straight when timing ceases will not be removed from the track. *'12 07 11*
- 7.5.4. The Chief Race Walk Judge must report to the Referee immediately after the end of the event, the details of all athletes disqualified AND all athletes who received red cards.
- a) At the LAQ Carnivals, Regional & State Championships, for U12 - U17 athletes, Race Walk Judges will not call 'Red Card' for relevant infringements, only written reports will be made. *BoD 14 ('14)*
- 7.5.5. At the completion of each Race Walk Event at all Association Competitions, the Chief Race Walk Judge's Recording sheet, with all individual judges reports / caution forms attached, is to be attached to the relevant paper work for that event. The Chief Judges sheet (with the Judge's names having been removed), is then copied, and displayed. *WULG 29 ('95)*
- 7.5.6. The organisers of walking events held on roads must ensure the safety of athletes and where possible, should ensure that the roads used for the competition are closed in both directions and not open to motorised traffic.
- 7.6. FIELD EVENTS**
- 7.6.1. Throwing implements owned by LAQ/LAQ Centres, QA and / or U13 - U17 individuals and certified by Trade Measurement (Office of Fair Trading), or a competent Official from LAQ/QA are to be allowed at all Association (except Regions) competitions. Any equipment provided by an individual must be added to the collective pool of the event equipment for use of all athletes in that event. Equipment provided by athletes will be at the athlete's own risk. The Association will take no responsibility for the loss or damage to equipment. *BoD 9 ('11)*
- The athletes and parents will be required to sign an agreement that the equipment shall be available for all athletes in their events to use without bias and a waiver against claim from damaged implements.
- 7.6.2. For Discus, all throws shall be made from an enclosure or cage to ensure the safety of spectators, officials and athletes. *'16 10 12*
- 7.6.3. At Regional Competitions (at the discretion of the Regional Committee), LAQ Carnivals, Combined Event, State Relays, Winter, and State Championship events, in order to obtain a better grip, an athlete in the U13 - U17 age groups may use a suitable chalk substance or similar substance that can be removed with a wet cloth. A Shot Putter may use such substances on their neck. In addition, in the Shot Put and Discus events athletes may use the substance on the implement. The only chalk substance to be used would be that provided by the Association. *'16 04 13*
- 7.6.4. Seeding of field event athletes / relay teams shall be random. *'15 08 11*

- 7.6.5. There will be one (1) only practice trial if time permits. This will be at the discretion of the Meeting Manager or his / her representative; and may only be conducted under the supervision of the appropriate Official. '15 08 11
- 7.6.6. At State Championships, High Jump athletes in the U13 - U17 age groups are allowed to do a practice jump at a height of their choice. The Chief would manage the warm-up time so that the bar was not constantly being raised and lowered. '11 04 13
- 7.6.7. Once competition has begun, athletes are not permitted to use, for practice purposes, the runway, implements, sectors or circles.
- 7.6.8. In all field events, including Combined Event competitions, athletes may not leave the immediate area of the competition during the competition unless they have the permission of, and are accompanied by an Official.
- 7.6.9. No athlete may enter the competition after the completion of the third round.
- 7.6.10. If an athlete incurs a foul, they will be given the reason for the foul at the completion of the trial.
- 7.6.11. If an athlete in the U13 to U17 age groups makes an immediate oral protest against having an trial judge as a failure, the Chief of the event may, at his discretion, order that the trial be measured and the results recorded, in order to preserve the rights of all concerned. At the end of the round the Referee will adjudicate on the protest
- a) Any athlete(s) continuing in a field event under protest shall compete in each round before any other athlete, irrespective of any improved performance in such subsequent rounds. '15 08 11
- 7.6.12. High Jump Starting Heights
- a) At Centre level, there should be no specific starting heights set for High Jump. The starting heights should be set at a level that all athletes can achieve.
- b) For all Association competitions (with the exception of Regional Relays and Regional Championships), the following starting heights for High Jump will be constant at:
- | | | | | | |
|------|------|-----|------|-----|------|
| *U9 | 0.80 | U12 | 1.10 | U15 | 1.30 |
| *U10 | 0.90 | U13 | 1.20 | U16 | 1.35 |
| U11 | 1.00 | U14 | 1.25 | U17 | 1.35 |
- c) Regional Relays and Regional Championships starting heights would be at:
- | | | | | | |
|------|------|-----|------|-----|------|
| *U9 | 0.75 | U12 | 1.05 | U15 | 1.25 |
| *U10 | 0.85 | U13 | 1.15 | U16 | 1.30 |
| U11 | 0.95 | U14 | 1.20 | U17 | 1.30 |
- *Scissors only
LAA ('15)
- d) Combined Event Championships starting heights shall be agreed upon by the Officials after consultation with the individual athletes. BoD 11 ('19)
- 7.6.13. High Jump Bar Increments
- a) State & Regional Relays: The bar will be raised 7cm, 7cm, 7cm and then by 5cm thereafter.
- b) At the Summer, Spring and Winter Carnivals, the Regional Championships, and State Championships (individual events) the increments for High Jump will be 5cm until six (6) athletes remain, then not less than 2cm. The last remaining athlete of an event, in consultation with the Chief, may elect the increments not less than 1cm.
- c) At the Regional Championships, increments will also include the State qualifying performance level, where there are more than four (4) athletes remaining in the competition. JIM 3 ('16)
- d) At the Combined Event Championships, the increments will be 3cm throughout the competition.
- e) The bar is never lowered for an athlete who has returned after competing in another event.
- 7.6.14. For High Jump, the Scissor technique will be the only allowable technique performed in High Jump for the Under 8, Under 9 and Under 10 age groups at all levels of competition. It shall be a valid scissor jump if all other relevant high jump rules are adhered to, and:
- a) The head of the athlete does not go over the bar before the leading foot (the foot of the leg closest to the bar at take-off);
- b) The head of the athlete is not below the buttocks when the buttocks clear the bar, and
- c) The athlete's lead foot touches the mat before any other part of the body.
- 7.6.15. For High Jump, all athletes in the Under 11 and above age groups will have the option to use any legal jumping technique where flop mats are provided at all levels of competition.

7.6.16. Ties and Countbacks

- a) In all field events, except for High Jump, the second (2nd) best performance of the athletes tying shall decide the tie. If a tie remains, the third (3rd) best and so on. If athletes in field events are tied for any place after all count backs have been applied, then equal placing will be declared.
- b) In High Jump ties, the athlete with the lowest number of jumps at the height at which the tie occurs shall be awarded the higher place. If the tie remains, the athlete with the lowest total of failures throughout the competition up to and including the height last cleared shall be awarded the higher place. If the tie remains, the athletes shall be awarded the same place in the competition. There shall be no jump-off for placing's.
- c) At the Regional and State Relays where two (2) or more teams' Best Performances are equal:
 - i. In High Jump relays, the sums of the 'number of trials at Best Height cleared" are used to separate the tied teams.
 - The team with the lowest total number of trials will be given the highest placing.
 - Should the tied teams still not be separated the sums of the 'total failures' of each of the tied teams, the team with the lowest total number of failures will receive the highest placing.
 - ii. In field relay events (other than High Jump), the combined second best performance of the same athletes tying shall decide the tie. If a tie remains, the combined third best performance will decide.

IPS 7 ('15)

7.7. BEST PERFORMANCES

- 7.7.1. Claims for Queensland and Australian Best Performances are only accepted from competitions controlled by LAQ or LAA i.e. the various LAQ Carnivals, Combined Event Championship, State Championships, State Relays, and the Little Athletics Australian Championships. Any Winter, Queensland, and / or Australian Best Performances (where applicable) will be subject to ratification.
- 7.7.2. Only LAQ registered members are eligible to hold a Winter Best Performances, Queensland Best Performance or Australian Best Performances.
- 7.7.3. Queensland Best Performances will not be recognised for individual performances recorded at the State Relays.
- 7.7.4. Queensland Best Performances will not be recognised for the U7 and U8 age groups.
- 7.7.5. Regional Best performances shall not be recognised for the U7 and U8 age groups.
- 7.7.6. The ground on which the Best Performance takes place must have been surveyed (compliant with WORLD ATHLETICS rules).
- 7.7.7. All equipment must comply with WORLD ATHLETICS rules and or LAQ rules.
- 7.7.8. Potential QBP distances or heights measured with a fiberglass tape or steel bar must be verified for accuracy against a steel tape after the event. The steel tape must be certified by an appropriate weights and measures authority.
- 7.7.9. Where an EDM unit is used to measure the distance, the check mark must be tested for accuracy prior to and after the competition against a certified steel tape.
- 7.7.10. If more than one athlete records the same distance or height in a field event, which attains the Best Performance, then those athletes shall be awarded a Best Performance irrespective of final placings.
- 7.7.11. If more than one athlete records the same time electronically, only the first and or best placed athlete shall be awarded the Best Performance.

8. CLASHING & CHANGE OR ABANDONED EVENTS

8.1. CLASH OF EVENTS

8.1.1. Where an athlete is in both a track and field event at the same time, track events take precedence. Every effort will be made by Officials to ensure all athletes receive their allotted trials at field events, but in this regard, Centres and Officials are requested to ensure that:

- a) Athletes in clashing events go back to their field event immediately after they have completed their track event, once instructed by the relevant Official.
- b) Athletes, whose clashing track event starts after the field event, remain at the field event until a few minutes before the track event starts when they will be collected by the relevant Official.
- c) Officials at both the track and field venues are advised of the clash so they may do their best to minimise its effect.

8.1.2. Except for High Jump, where a clash of events occurs, the Chief Judge may allow the athlete to compete out of round and out of order in all rounds. It is not permitted for an athlete to have two or more consecutive trials, nor can an athlete demand to have a trial that has been missed.

Note: The first three rounds of trials must be completed, and a final eight determined prior to any other subsequent rounds of trials being commenced. LAA ('17)

8.1.3. For High Jump, where a clash of events occurs, the Chief Judge may allow the athlete to compete out of order. The athlete re-joins the competition at the current height of the bar.

Note: The bar will not be lowered to the height at which they left, nor will the event be stopped while they are away. LAA ('17)

8.1.4. Neither track nor field events can be unduly delayed to suit individual athletes.

8.2. CHANGE OF COMPETITION AREA

8.2.1. The Referee in consultation with the Field Event Chief, Meeting Manager, or Event Venue Manager shall have power to change the place of competition (venue) during competition, for a field event due to adverse conditions that may put the safety of athletes and / or Officials at risk. Such change should only be made after a round is completed, or if circumstances dictate that it is impossible to complete the round. The event shall resume at the new place of competition from the last completed round.

8.3. ABANDONED ASSOCIATION COMPETITIONS / EVENTS

8.3.1. Any three (3) Board Directors or any two (2) Board Directors plus Chief Executive Officer, taking into account the recommendation of the Meeting Manager and Referees, will make any decision with regard to re-scheduling or abandoning events for any Association Day. Paramount in the decision to continue or otherwise should be the safety of the athletes. If a competition day proceeds with a late start, provision to use the lights, if required, should be available through the Facility. State Championships will only be abandoned in the most extreme conditions. This does not apply to Regional competitions.

8.3.2. The Regional Competition Coordinator, taking into account the recommendation of the Meeting Manager and Referees, and after due consultation with ALL Centre Managers or authorised Centre representatives, will make any decision with regard to re-scheduling or abandoning a Regional Championships or Regional Relays. If the decision is to abandon an event(s) / competition, where possible, the backup date MUST be used to reschedule the event(s) / competition. Paramount in the decision to continue or otherwise, should be the safety of the athletes.

8.3.3. Abandoned Regional Championships: Current season Best Performances from Centre level and any Association Competition Days with the exception of Relay days, must be used when selecting athletes to compete at State Championships. Athletes without a Best Performance may not be considered for progression to the State Championships. '20 03 10

- a) In events where there are four or less athletes, athletes without a best performance may progress to the State Championships. BoD 11 ('13)
- b) Prior to the selection of advancing / qualifying athletes, the current season track performances for 70m - 400m must be rounded up to the next highest 1/10.

- 8.3.4. In the event of the program being abandoned during the day, all events completed, including track events where finalists have been selected, and completed rounds of field events, shall stand.
- 8.3.5. If a field event, except High Jump, is not restarted, and all athletes have completed at least half the number of rounds allowed, then that event shall be deemed to have been finished, and results shall be based on performances over the completed rounds only.
- 8.3.6. In a High Jump event where there are six (6) or less athletes in the event when it is stopped, then the event shall be deemed to have been finished and results based on performances recorded after the last completed round.
 - a) Where the number of athletes exceeds six (6) and the event is restarted then only those athletes who have not been disqualified from further jumping shall be eligible to continue in the event. The event restart shall have the bar set one (1) increment above the height set for the last full round of jumps completed before the event was stopped. A full round is one, which includes an athlete passing their turn by choice.
- 8.3.7. Any other variations on the day of competition shall be at the discretion of the Association Board of Directors, through the authorised Officer of the Association. (This will normally be the Competition Manager, or at Regional Level, the Regional Competition Coordinator after consultation with all or majority of Centre Managers within the Region.)

9. PROTESTS / DISQUALIFICATIONS / APPEALS

9.1. GENERAL

- 9.1.1. Protests may only be lodged at the Combined Event Championships, the State Relays & State Championships, the Regional Relays & Regional Championships. '20 03 10
- 9.1.2. No person other than the Team Manager as the representative so nominated by the Centre shall be entitled to query decisions, or lodge protests or appeals.
- 9.1.3. Any Centre failing to comply with this rule will forfeit the right to protest or appeal. Team Managers names MUST be signed in with the Regional Competition Coordinator (Regional Competitions) / Information area (Association Competitions).

9.2. PROTESTS

- 9.2.1. Where an athlete is allowed to continue competing under protest, any subsequent performance will only be valid if the protest (or appeal) is eventually upheld in his favour.
- 9.2.2. Protests must be made verbally by the Team Manager to staff in the Information tent within fifteen (15) minutes of the completion of the event and then lodged in writing (using the proforma supplied) within another fifteen (15) minutes (i.e. 30 minutes total) from the completion of the event. ASH 7 ('93)
- 9.2.3. Each protest must be recorded on the proper form at the time of verbal lodgment. The written protest must include the name and number of the event upon which the protest is lodged and indicate the names of all Centres involved in the incident and relevant rule under which the protest is to be investigated, as well as any other relevant information.
- 9.2.4. A deposit of \$55.00 (incl. GST) is payable at the time the verbal protest is lodged.
 - a) Protest money will not be refunded unless the protest is successful.
- 9.2.5. That in the event of a protest at Championships, an announcement will be made, that a protest has been lodged. An announcement of the decision will also be made. C32 ('87)
- 9.2.6. Once the protest has been handed to the Referee, the Team Manager will wait at the Information tent until the Referee has made all necessary enquiries, after which the Referee will advise that Team Manager involved of their decision.
- 9.2.7. The Referee may decide on receipt of a protest or an appeal lodged on the prescribe form, to consult video evidence if available. '20 03 10
- 9.2.8. The Referee may decide on the protest or may refer the matter to the Jury of Appeal.
- 9.2.9. If the Referee makes the decision, there shall be a right of appeal to the Jury of Appeal by the Team Manager.

- 9.2.10. If the Referee decides to dismiss the protest, he shall advise the protesting Team Manager accordingly.
- 9.2.11. If the Referee decides he will uphold the protest, he shall call together all the Team Managers involved i.e. Team Managers from Centres whose placings will change and advise them all at the same time of his decision, note the decision and the time on the protest sheet and subsequently hand it to the staff in the Information tent.
- 9.2.12. For relevant procedures should any of the Team Managers involved disagree with this decision, refer to "APPEALS".

9.3. DISQUALIFICATION BY A REFEREE

- 9.3.1. If an athlete is disqualified in an event because of an infringement of the rules with regard to that event, results achieved up to that disqualification stand, and that disqualification shall not prevent the athlete from taking part in all other events. An athlete acting in an unsporting or improper manner may be disqualified from participation in all future events in the competition.
- 9.3.2. In Race Walking events, an athlete may be disqualified by the Chief Race Walks Judge for infringements of the Race Walking rules or by the Referee for failure to comply with other rules for the conduct of events.
- 9.3.3. In deciding on infringements, Referees may consult with the athletes and other Officials involved, before making decisions. '17 01 11
- 9.3.4. If a Referee disqualifies an athlete or team in the U7 to U12 age groups, for an infringement of the rules, he must take every reasonable effort to notify the respective Centre Team Manager. The call for the relevant Team Manager to report to the Referee will be given to the Announcer, and a verbal report be given to the Team Manager by the Referee. The Referee will notify athletes in the U13 to U17 age groups directly regarding their disqualification. '15 07 07
- 9.3.5. It will be necessary for the Referee to prepare a written report (using the proforma supplied), detailing circumstances surrounding the disqualification and stipulating the time the disqualification took place.
- 9.3.6. For relevant procedures, should any Team Manager disagree with this decision, refer to "APPEALS".
- 9.3.7. The appropriate Referee may warn or exclude an athlete guilty of acting in an unsporting or improper manner. The athlete may be disqualified if this behaviour is repeated.
- 9.3.8. The Competition Manager will notify the athlete's Centre Team Manager. If the Team Manager is not present at the Competition, a letter will be sent to the Centre.
- 9.3.9. If such behaviour is exhibited and recorded at a Regional competition, the Association is to be notified by the Regional Competition Coordinator. The information will be passed on to the Competition Manager of the next Association Carnival.

9.4. APPEALS

- 9.4.1. The Jury of Appeal shall be comprised of the Regional Competition Coordinator (Regional Competitions) / Board appointee (LAQ Championships) as Chairman and three (3) independent Association members i.e. any Centre not named / involved directly in the protest or appeal; including the Centre of the Official directly involved in the original ruling. No member of the jury will enter into any discussion or voice any opinion on the protest outside the jury room.
 - a) Six (6) to eight (8) LAQ members may be appointed at the beginning of each Competition season to be part of a Jury of Appeal pool that can be called upon when/if required at LAQ Championship events. '11 04 13
- 9.4.2. Should any Team Managers wish to take any Referee's decision further (i.e. to the Jury of Appeal), they must advise the Referee (verbally) immediately he hands down his decision, and within fifteen (15) minutes submit the appeal to the Announcer in writing (using the proforma supplied).
- 9.4.3. The Announcer will check the time of receipt and providing everything is in order, will announce an appeal has been made.
- 9.4.4. Once an appeal or other matter has been referred to the Jury of Appeal for decision, the Referee shall supply all the relevant information that is available and the reason for his decision. In no case shall a Team Manager or any other person, Athlete or Official, approach the Jury of Appeal except by invitation. The Jury will try to ensure they obtain input from all relevant sources.

- 9.4.5. To arrive at a fair decision, the Jury of Appeal may consult all available evidence and interview all those whom they consider necessary. *BoD 9 ('15)*
- a) Video evidence shall not be used for Race Walking events in the deliberation of protests / appeals lodged in relation to breaches of the contact or knee rules. *'15 08 11*
- 9.4.6. If an appeal is upheld, the Team Managers of all affected Centres must be informed of the decision before any public announcement is made, so that they may inform the athletes involved directly.
- 9.4.7. An announcement of the decision will subsequently be made.
- 9.4.8. The Jury's decision is final and no subsequent discussion or correspondence will be entered in to.

10. OFFICIALS

10.1. APPOINTMENT OF OFFICIALS

- 10.1.1. Trainee Officials cannot hold Chief Judges duties at State Relays or State Championships. All other duties can be performed for practical assessment but not the duties of the Chief Official.
- 10.1.2. That the Board of Directors be required to (give) preference to appointment of Officials from personnel involved in Little Athletics, unless qualified people from within the movement are unavailable and or unwilling to act. *02 ('86)*

10.2. TEAM MANAGERS

- 10.2.1. The Team Manager shall not be a Competition Official.
- 10.2.2. Each competing Centre shall designate one or more person(s) to be their Team Manager at an Association Competition where Centre athletes have been nominated, using the prescribed process. The Team Manager(s) must be present at the arena, before the commencement of and during events in which the Centre's athletes are competing and be responsible for:
- a) Ensuring that all competing Centre athletes at Association Competitions are aware of the event times, as well as the Call Time for their respective events.
- b) Ensuring that all athletes report to the Call Room / event areas once they have been called.
- c) Ensuring that all athletes are correctly attired in the Centre uniform before being marshaled for events.
- d) Advising the relative Call Room Judge(s) and Chief Recorder if an athlete withdraws from any events.